

# ENDAT-7500M/7515M

## *User Manual*

2008/3/25  
Rev. A1

### Copyright Notice

The content of this manual has been checked for accuracy. The manufacturer assumes no responsibility for any inaccuracies that may be contained in this manual. **The manufacturer reserves the right to make improvements or modification to this document and/or the product at any time without prior notice.** No part of this document may be reproduced, transmitted, photocopied or translated into any language, in any form or by any means, electronic, mechanical, magnetic, optical or chemical, without the prior written permission of the manufacturer.

VIA C7® is registered trademark of VIA Technology Incorporation  
VT8237R Plus may only be used to identify products of VIA Technology  
Multiscan is a trademark of Sony Corp of America  
IBM, EGA, VGA, PC/XT, PC/AT, OS/2 and PS/2 are registered trademarks of International Business Machines Corporation  
Plug and Play is registered trademarks of Intel Corporation  
Microsoft, Windows and MS-DOS are trademarks of Microsoft Corporation  
Award is a trademark of Phoenix Software Inc.  
PCI is a registered trademark of PCI Special Interest Group  
All trademarks are the properties of their respective owners.

Other product names mentioned herein are used for identification purpose only and may be trademarks and/or registered trademarks of their respective companies.

### Installation Notice

The manufacturer recommends using a grounded plug to ensure proper motherboard operation. Care should be used in proper conjunction with a grounded power receptacle to avoid possible electrical shock. All integrated circuits on this motherboard are sensitive to static electricity. To avoid damaging components from electrostatic discharge, please do not remove the board from the anti-static packing before discharging any static electricity to your body, by wearing a wrist-grounding strap. The manufacturer is not responsible for any damage to the motherboard due to improper operation.

**Specification:**

Model	ENDAT-7500M / ENDAT-7515M
<b>Form Factor</b>	Mini-ITX 170 mm x 170 mm (6.69"x6.69") with 6 layers PCB
<b>System Chipset</b>	VIA CN700(NB/2.5W)+ VIA VT8237R Plus (SB/1.8W)
<b>CPU Supporting</b>	<b>ENDAT-7500M:</b> VIA V4 EDEN ULV 500MHz(1W) <b>ENDAT-7515M:</b> VIA V4 C7-D 1.5GHz (20W)
<b>Memory</b>	One 240Pin DDRII 533/400 DIMM up to 1GB
<b>Ethernet</b>	VT8237R Plus integrated 10/100 Fast Ethernet w/ VT6103 (PHY)
<b>VGA</b>	Integrated VIA UniChrome Pro 3D / 2D Graphics with SMA 16/32/64MB
<b>Video Interface</b>	Integrated MPEG-2(DVD/DVB) Hardware decoder
<b>Serial / Parallel RS-422/485</b>	4 Serial Port w/ +5V, +12V Power Selector / 2 Parallel port Via COM2 (Optional)
<b>Watchdog Timer</b>	Programmable WDT from 1 to 255 seconds / minutes by Winbond W83697HG
<b>IDE Connector</b>	1 x 40pin IDE connector support UDMA 33/66/100/133, 1 x 44pin connector support Slim type HDD
<b>SATA Connector</b>	2 x 150MB/s SATA device support Raid 0, 1, JBOD
<b>Expansion Slot</b>	1x 32bits PCI slot
<b>Back Panel I/O</b>	PS/2 Keyboard / Mouse Connector
	2 USB port + RJ-45 LAN Connector(10/100)
	VGA, LPT1 and COM1/COM2/COM3 with D-Sub connector
	LPT2 with 2.0mm Box Header
	COM4 with 2.54mm Box Header
	1 IrDA TX/RX port with Pin Header
<b>Power Supply</b>	Pin Header for KB/MS, 4 x USB, SPDIF-IN/OUT, SM Bus, KB/MS for external device ATX power supply

**TABLE OF CONTENTS**

<b>CHAPTER 1. INTRODUCTION .....</b>	<b>1</b>
1-1. FEATURES .....	2
1-2. UNPACKING .....	3
1-3. ELECTROSTATIC DISCHARGE PRECAUTIONS .....	3
1-4. MOTHERBOARD LAYOUT .....	4
<b>CHAPTER 2. SETTING UP THE MOTHERBOARD .....</b>	<b>5</b>
2-1. JUMPERS AND CONNECTORS .....	5
2-2. INSTALLING MEMORY .....	13
2-3. SHARED VGA MEMORY .....	13
2-4. ASSIGNING IRQs FOR EXPANSION CARDS .....	13
2-5. WATCHDOG TIMER .....	14
<b>CHAPTER 3. AWARD BIOS SETUP .....</b>	<b>16</b>
3-1. STANDARD CMOS FEATURES .....	17
3-2. ADVANCED BIOS FEATURES .....	18
3-3. ADVANCED CHIPSET FEATURES .....	19
3-4. INTEGRATED PERIPHERALS .....	21
3-5. POWER MANAGEMENT SETUP .....	24
3-6. PnP/PCI CONFIGURATIONS .....	26
3-7. PC HEALTH STATUS .....	27
3-8. FREQUENCY/VOLTAGE CONTROL .....	28

<b>CHPATER 4. VGA, LCD, FEATURE.....</b>	<b>29</b>
4-1. VGA FEATURE.....	29
4-2. DRIVER UTILITY INSTALLATION GUIDE.....	30
<b>CHPATER 5. LAN ADAPTER.....</b>	<b>32</b>
5-1. FEATURES .....	32
5-2. UTP CABLE/RJ-45 JACK DEFINITION.....	33
5-3. CONNECTING 100BASE-TX FAST ETHERNET NETWORK .....	34
5-4. CONNECTING 10BASE-T ETHERNET NETWORK .....	34
5-5. 10MBASE/ 100MBASE INSTALLATION NOTICE .....	34
5-6. REMOTE BOOT ROM FUNCTION .....	35
5-7. LED INDICATORS.....	35
<b>APPENDIX A: FLASH MEMORY UTILITY.....</b>	<b>36</b>
<b>APPENDIX B: LIMITED WARRANTY .....</b>	<b>37</b>

## Chapter 1. Introduction

ENDAT-7500M/7515M supports high performance processor of VIA C7 processor. It also supports high speed DDR memory with 64-bit wide interfaces with non-ECC DIMM (up to 1GB). Only Double Data Rate (DDRII) SDRAM memory is supported and the speed of memory can be 400 and 533 MHz.

ENDAT-7500M/7515M provides an integrated graphics (S3 Graphics UniChrome™ Pro IGP) accelerator delivering cost competitive 3D, 2D, and video capabilities.

In addition to the integrated S3 Graphics UniChrome™ Pro IGP, featuring a 2D/3D AGP8X graphics core with integrated MPEG-2 decoding for smooth DVD and digital video playback, the VIA C7® processing platform also features support for high bandwidth DDRII 400/533 MHz memory, motion compensation and DuoView for the latest multiple format flat panel display devices.

ENDAT-7500M/7515M with native dual channel Serial ATA/RAID controller provides direct support for two 150MB/s Serial ATA devices. The V-RAID controller features native RAID 0, RAID 1 and JBOD support, ensuring optimum data integrity and system performance. The user-friendly V-RAID software interface enables easy disk array configuration and management.

ENDAT-7500M/7515M supports IEEE 802.3 compliant 10 / 100 Mbps PCI bus master Ethernet MAC with standard MII interface to external PHYceiver.

### The ideal solution of ENDAT-7500M/7515M

- POS system
- KIOSK
- Interactive system
- Airport Terminal Controller
- Industrial controller
- Digital entertainment
- Embedded system equipment

## 1-1. Features

### Basic Feature:

- Board format: Mini-ITX (170mm x 170 mm)
- Supports 400/533 MHz FSB by VIA C7®
- Supports DDRII 400/533 MHz SDRAM up to 1GB
- Serial ATA connector x 2
- Enhance 40 Pin IDE connector x 1; 44 Pin IDE connector x 1
- Multiple I/O ports: COM port x 4; USB (2.0) x 6
- All COM ports with +5V, +12V power selector
- Watchdog Timer
- VIA 10/100 LAN and Audio function onboard
- With Intel embedded ATX PCI expansion design
- Support ATX Power Supply

### Optional features:

- RS 422/485 via COM 2

### Full Software Support:

- Drivers for major operating systems and APIs: Windows 2000, Windows XP, Direct3D, DirectDraw and DirectShow, OpenGL ICD for Windows 2000, and DXVA for Windows 2000 and Windows XP

## 1-2. Unpacking

The motherboard comes securely packaged in a sturdy cardboard shipping carton. In addition to the User's Manual, the motherboard package includes the following items:

ENDAT-7500M/7515M System Board

HDD / IO Cables

CDROM Driver includes: Drivers for Windows 2000, XP and AMI/AWARD FLASH ROM utilities.

If any of these items are missing or damage, please contact the dealer from whom you purchase the motherboard. Save the shipping material and carton in the event that you want to ship or store the board in the future.

**Note:** Please leave the motherboard in its original package until you are ready to install it!

## 1-3. Electrostatic Discharge Precautions

Make sure you properly ground yourself before handling the motherboard, or other system components. Electrostatic discharge can easily damage the components. Note: You must take special precaution when handling the motherboard in dry or air-conditioned environments.

## 1-4. Motherboard Layout

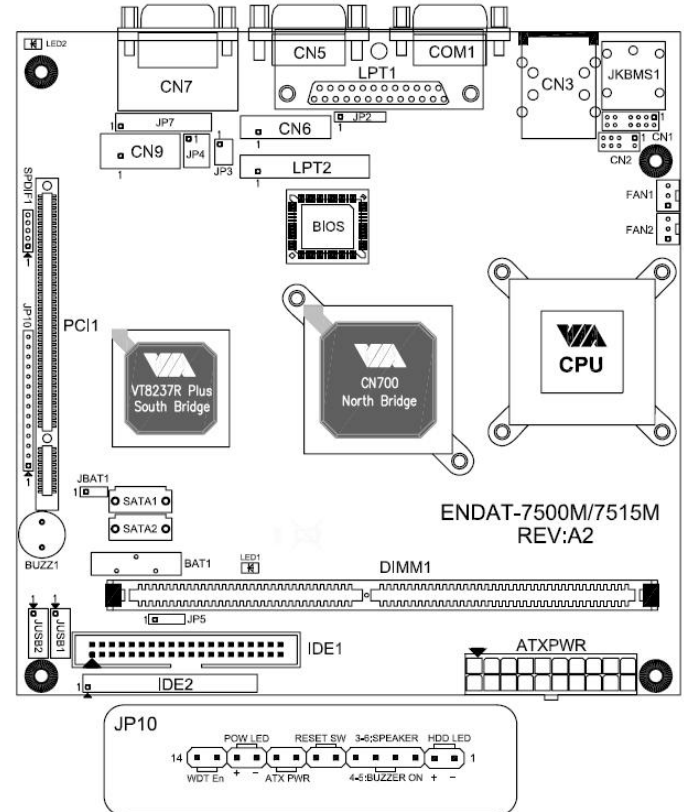

## Chapter 2. Setting up the Motherboard

### 2-1. Jumpers and Connectors

#### Jumpers/Connectors Overview:

Function	Jumpers/Connectors
ATX Power Connector	ATXPWR
Cooling Fan Connector	FAN1, FAN2
Buzzer	BUZZ1
Battery	BAT1
Clear CMOS	JBAT1
DDR2 SDRAM socket	DIMM1
IR Pin Header	JP2
PS/2 MS/KB Pin Header	CN2
PS/2 MS/KB Connector	JKBMS1
OEM MS/KB Pin Header	CN1
USB Port	CN3, JUSB1, JUSB2
Pin Header for Case Panel	JP10
HDD active LED	JP10: Pin 1(-), Pin 2(+)
External Speaker	JP10: Pin 3, Pin 6
Buzzer On/Off	JP10: Pin 4, Pin 5
Hardware Reset Switch	JP10: Pin 7, Pin 8
ATX Power Supply On/Off Switch	JP10: Pin 9, Pin 10
Power LED	JP10: Pin 11(-), Pin 12(+)
WDT Function Enable/Disable	JP10: Pin 13, Pin 14
LAN Connector	CN3
CRT Output	CN5
CRT Box Header	CN6
COM1	COM1
COM2, COM3	CN7
COM4 Box Header	CN9
COM Port Voltage Selector	JP7
RS232 / 422/ 485 Selector for COM2	JP3 & JP4
SMBus Pin Header	JP5
PCI SLOT	PCI1
LPT1, LPT2	LPT1, LPT2
SATA 1, SATA 2	SATA1, SATA2

Function	Jumpers/Connectors
40-Pin IDE Connector	IDE1
44-Pin IDE Connector	IDE2
SPDIF Pin Header	SPDIF1
DIMM Power LED	LED1
System Power LED	LED2

*Please double-check the insertion and orientation of the LCD cable before applying power. Improper installation will result in permanent damage LCD panel.*

### Part 1: Onboard Jumpers

#### JBAT1: CMOS Data Clear (2.0mm)

Pin No.	Function
Pin 1-2	Normal (Default)
Pin 2-3	Close for clear CMOS

#### JP1: LVDS Voltage Selector (2.0mm)

Pin No.	Function
Pin-1, 2 *	+3.3V
Pin-3, 4	+5V
Pin-5, 6	+12V

*Caution: Improper setting will damage LCD panel.*

#### JP10: Pin Header for Case Panel (2.54mm)

Pin No.	Function
1(-), 2(+)	HDD active LED
3,6	External Speaker
4,5	Buzzer On/Off
7,8	Hardware Reset Switch
9,10	ATX Power On/Off
11(-),12(+)	Power LED
13,14	Close: Enable WDT function

**JP3, JP4: RS232 / 422 / 485 Selector for COM2 (2.0mm)**

TYPE	JP3 (2x3/2mm)	JP4 (3x4/2mm)
RS-232 *	1-2	1-2, 4-5, 7-8, 10-11
RS-422	3-4	2-3, 5-6, 8-9, 11-12
RS-485	5-6	2-3, 5-6, 8-9, 11-12

**JP7: COM Port Voltage Selector (2.0mm)**

Voltage	+12V(DC)	R.I. *	+5V(DC)
COM1 (JP7)	1-2	3-4	5-6
COM2 (JP7)	7-8	9-10	11-12
COM3 (JP7)	13-14	15-16	17-18
COM4 (JP7)	19-20	21-22	23-24

**Part 2: Onboard connectors****JP2: IR Pin Header Connector (2.54mm)**

Pin No.	Function	Pin No.	Function
Pin 1	VCC	Pin 4	GND
Pin 2	N.C	Pin 5	IRTX
Pin 3	IRRX		

**JP5: SM Bus Pin Header (2.0mm)**

Pin No.	Function	Pin No.	Function
1	SMBCK	3	+3.3V
2	SMBDT	4	GND

**SPDIF1: SPDIF Box Header Connector (2.0mm)**

Pin No.	Function	Pin No.	Function
1	+5V	4	GND
2	N.C.	5	SPDIFIN
3	SPDIFOUT		

**CN1: Pin Header for external device (2.0mm)**

Pin No.	Signal (KB)	Pin No.	Signal (MS)
1	KB Data Out	2	MS Data Out
3	KB Data In	4	MS Data In
5	KB CK Out	6	MS Data Out
7	KB CK In	8	MS CK In
9	KEY	10	KEY
11	+5V(DC)	12	+5V(DC)
13	GND	14	GND

**CN2: PS/2 Keyboard / Mouse Pin Header Connector (2.0mm)**

Pin No.	Signal (KB)	Pin No.	Signal (MS)
1	KB Data	2	MS Data
3	KEY	4	KEY
5	GND	6	GND
7	+5V(DC)	8	+5V(DC)
9	KB_CLK	10	MS_CLK

**CN6: CRT Box Header Connector (2.0mm)**

Pin No.	Description	Pin No.	Description
1	RED	9	N.C / +5V
2	GREEN	10	GND
3	BLUE	11	N.C.
4	N.C.	12	DDC DAT
5	GND	13	H-Sync
6	GND	14	V-Sync
7	GND	15	DDC CLK
8	GND		

**FAN1, FAN2: CPU / 2nd Cooling Fan Connector**

Pin No.	Function
1	GND
2	+12V
3	Sensor Pin

**ATXPWR: ATX Power connector**

		ATX			
3.3V	11	1	3.3V		
-12V	12	2	3.3V		
GND	13	3	GND		
PS ON	14	4	+5V		
GND	15	5	GND		
GND	16	6	+5V		
GND	17	7	GND		
-5V	18	8	POWER OK		
+5V	19	9	5V SB		
+5V	20	10	+12V		

**LPT2: Printer (LPT2) Port Box Header (2.0mm)**

Pin No.	Description	Pin No.	Description
1	STB#	10	ACK#
2	PD0	11	BUSY
3	PD1	12	PE
4	PD2	13	SLCT
5	PD3	14	AFD#
6	PD4	15	ERR#
7	PD5	16	INIT#
8	PD6	17	SLIN#
9	PD7	18-25	GND

**JUSB1 JUSB2: Pin Header Type Connector for USB port (2.54mm)**

Pin No.	Function	Pin No.	Function
1	USB_VCC	2	USB_VCC
3	USB2-/4-	4	USB3-/5-
5	USB2+/4+	6	USB3+/5+
7	USB_GND	8	USB_GND
9	USB_GND	10	USB_GND

**CN9: Box Header Type Connector for COM4 port (RS-232) (2.54mm)**

Pin No.	Function	Pin No.	Function
1	DCD	6	DSR
2	RXD	7	RTS
3	TXD	8	CTS
4	DTR	9	RI
5	GND	10	N.C.

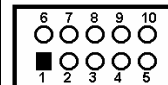
**D-SUB Type Connector for COM1 ~ COM3 port (RS-232)**

Pin No.	Description	Pin No.	Description
1	DCD	6	DSR
2	RXD	7	RTS
3	TXD	8	CTS
4	DTR	9	RI
5	GND		

**D-SUB Type Connector for COM2 port (RS-422→ 4 Wire)**

Pin No.	Function	Pin No.	Function
1	-TXD	6	NA
2	+RXD	7	NA
3	+TXD	8	NA
4	NA	9	-RXD
5	NA		

**D-SUB Type Connector for COM2 port (RS-485→ 2 Wire)**

Pin No.	Function	Pin No.	Function
1	Data -	6	NA
2	NA	7	NA
3	Data +	8	NA
4	NA	9	NA
5	NA		

**IDE1: IDE1 Connector (40Pins)**

Pin No.	Description	Pin No.	Description
1	IDE Reset#	2	GND
3	IDE data7	4	IDE data8
5	IDE data6	6	IDE data9
7	IDE data5	8	IDE data10
9	IDE data4	10	IDE data11
11	IDE data3	12	IDE data12
13	IDE data2	14	IDE data13
15	IDE data1	16	IDE data14
17	IDE data0	18	IDE data15
19	GND	20	N.C.
21	IDE REQ	22	GND
23	IDE IOW#	24	GND
25	IDE IOR#	26	GND
27	IDE Ready	28	GND
29	IDE ACK#	30	GND
31	IDE IRQ	32	N.C.
33	IDE A1	34	P66DET
35	IDE A0	36	IDE A2
37	IDECS1#	38	IDESC3#
39	HDLED#	40	GND

**IDE2: Slim IDE2 Connector (44Pins with 2.0mm)**

Pin No.	Description	Pin No.	Description
1	IDE Reset#	2	GND
3	IDE data7	4	IDE data8
5	IDE data6	6	IDE data9
7	IDE data5	8	IDE data10
9	IDE data4	10	IDE data11
11	IDE data3	12	IDE data12
13	IDE data2	14	IDE data13
15	IDE data1	16	IDE data14
17	IDE data0	18	IDE data15
19	GND	20	N.C.
21	IDE REQ	22	GND
23	IDE IOW#	24	GND
25	IDE IOR#	26	GND
27	IDE Ready	28	GND
29	IDE ACK#	30	GND
31	IDE IRQ	32	N.C.
33	IDE A1	34	P66DET
35	IDE A0	36	IDE A2
37	IDECS1#	38	IDESC3#
39	HDLED#	40	GND
41	VCC(+5V)	42	VCC(+5V)
43	GND	44	N.C.

## 2-2. Installing Memory

ENDAT-7500M/7515M system board offers one 240 pin DDRII SDRAM socket supports up to 1GB memory and the speed can be 400 and 533 MHz.

## 2-3. Shared VGA Memory

ENDAT-7500M/7515M is using built-in AGP VGA controller with S3 Graphics UniChrome Pro IGP graphics core **up to 64MB** of system memory. The amount of video memory on motherboard determines the number of colors and the video graphic resolution.

## 2-4. Assigning IRQs for Expansion Cards

Some expansion cards require an IRQ (Interrupt request vector) to operate. Generally, each IRQ must be exclusively assigned to specific use. In a standard design, there are 16 IRQ available with 11 of them already in used by other part of the system.

Some PCI expansion cards need IRQ; any remaining IRQ could be assigned to PCI Bus. Microsoft's Diagnostic (MSD.EXE) utility included in the Windows directory can be used to see their map. Clients can not have more than one device apply the same IRQ in the system or it will cause the system hang up, crash, and unexpected results. To simplify the process, this motherboard complies with the Plug and Play (PnP) specifications, which was developed to allow automatic system configuration. Whenever a PnP-compliant card is added to the system, PnP card and IRQs will automatically assigned if available. The PCI and PnP configuration in the BIOS setup utility can indicate which IRQs have being used by Legacy cards.

In the PCI Bus design, the BIOS is automatically assigned an IRQ to a PCI slot that has a card in it which requires an IRQ. To install PCI cards via riser card, you need to set the correct "ADSEL" and "INT" (interrupt) assignment on the jumper of riser card.

IRQ	Status	Assignment
0	Used	Timer
1	Used	Keyboard
2	Used	Second 8259
3	Used	COM2
4	Used	COM1
5	Used	COM3
6	Used	Floppy Disk
7	Used	LPT1
8	Used	RTC
9	Used	LPT2 or Audio
10	Used	COM4
11	Used	LAN Adapter (on board)
12	Used	PS/2 Mouse
13	Used	Coprocessor
14	Used	Hard Disk (IDE 1)
15	Used	Reserved (IDE 2)

## 2-5. Watchdog Timer

Watchdog Timer (WDT) is a special design for system monitoring to secure the system work normally. WDT has an independent clock from the oscillator and could set time and clear/refresh WDT counter function. When time is up, WDT will send hardware RESET signal to reset system.

### Timeout Value Range

-1 to 255

-Second or Minute

**Program Sample**

```

#include <stdio.h>
#include <dos.h>
#include <dir.h>
void show_ver();
void main()
{
    unsigned int tt;
    clrscr();
    show_ver();
    tt=0;
    while((tt==0)||((tt>255)))
    {
        printf("\n\nPlease key in how many seconds you want to reset system
(1~255):");
        scanf("%d",&tt);
    }
    outportb(0x2e,0x87); //Unlock register
    outportb(0x2e,0x87); //Unlock register
    outportb(0x2e,0x07); //Set Logic Device number pointer
    outportb(0x2f,0x08); //Set Logic Device number
    outportb(0x2e,0x29); //set active reg is cr29
    outportb(0x2f,0x20); //set reg value Pin119 Fun (bit5:6=01 WDTO)
    outportb(0x2e,0x30); //set active reg is CR30
    outportb(0x2f,0x01); //set reg value MIDI & GP5 active (bit0 =1 active,0
inactive )
    outportb(0x2e,0xf3); //Set active register is CRF3
    outportb(0x2f,0x00); //Set register value (bit2=1: minute. =0: second)
    outportb(0x2e,0xf4); //Set active register is CRF4
    outportb(0x2f,tt); //Set time out value of WDT
}

void show_ver()
{
    unsigned char tmp0;
    printf("Designed by ROBERT LIU of UNICORN computer corp.
\n2005/10/07 release version:1.0a\n");
    printf("This program is design for test Watch Dog Timer for
ENDAT-7500M/7515M(W83697HF).\n");
}

```

**Chapter 3. AWARD BIOS SETUP****Phoenix – Award BIOS CMOS Setup Utility**

<ul style="list-style-type: none"> <li>&gt; Standard CMOS Features</li> <li>&gt; Advanced BIOS Features</li> <li>&gt; Advanced Chipset Features</li> <li>&gt; Integrated Peripherals</li> <li>&gt; Power Management Setup</li> <li>&gt; PnP/PCI Configurations</li> <li>&gt; PC Health Status</li> </ul>	<ul style="list-style-type: none"> <li>&gt; Frequency/Voltage Control</li> <li>Load Optimized Defaults</li> <li>Set Supervisor Password</li> <li>Set User Password</li> <li>Save &amp; Exit Setup</li> <li>Exit Without Saving</li> </ul>
--	---

Use the CMOS setup program to modify the system parameters to reflect the environment installed in your system and to customize the system as desired. Press the <DEL> key to enter into the CMOS setup program when you turn on the power. Settings can be accessed via arrow keys. Press <Enter> to choose an option to configure the system properly.

In the main menu, press F10 or “SAVE & EXIT SETUP” to save your changes and reboot the system. Choose “EXIT WITHOUT SAVING” to ignore the changes and exit the setup procedure. Pressing <ESC> at anywhere during the setup will return to the main menu.

“Advanced BIOS Features”, “Advanced Chipset Features” and “PnP/PCI Configurations” requires board knowledge on PC/AT system architecture and Intel chipset specification. Incorrect setup could cause system malfunctions.

### 3-1. Standard CMOS Features

The Standard Setup is used for the basic hardware system configuration. The main function is for Data/Time and Hard Disk Drive settings.

Item	Available Options:
Date (mm:dd:yy)	
Time (hh:mm:ss)	
IDE Channel 0 Master:	Auto
IDE Channel 0 Slave :	Auto
IDE Channel 1 Master:	Auto
IDE Channel 1 Slave :	Auto
IDE Channel 2 Master :	Auto
IDE Channel 3 Master :	Auto
Video	EGA/VGA
Halt On	All , But Keyboard

#### • Video

Select the type of primary video subsystem.

<Choice: EGA / VGA, CGA 40, CGA 80, MONO>

#### • Halt On

Set the system's response to specific boot errors.

<Choice: All Errors, No Errors, All, But Keyboard>

#### IDE Drives

Item	Available Options:
IDE HDD Auto-Detection	Press Enter
IDE Channel	Auto
Access Mode	Auto

The specifications of your drive must match with the drive table. The hard disk will not work properly if you enter incorrect information in this category. Select "Auto" whenever possible. If you select "Manual" make sure the information is from your hard disk vendor or system manufacturer.

### 3-2. Advanced BIOS Features

This section allows you configuring your system for basic operation. You have the opportunity to select the system's default speed, boot-up priority, keyboard operation and security.

Item	Available Options:
>CPU Feature	
>Hard Disk Boot Priority	
Virus Warning	Disabled
CPU L1 & L2 Cache	Enabled
CPU L2 Cache ECC Checking	Enabled
Quick Power On Self Test	Enabled
First Boot Device	Hard Disk
Second Boot Device	CDROM
Third Boot Device	LS120
Boot Other Device	Enabled
Boot Up NumLock Status	On
Typematic Rate Setting	Disabled
Typematic Rate (Chars/Sec)	6
Typematic Delay (Msec)	250
Security Option	Setup

#### CPU Feature

Item	Available Options:
Delay Prior to Thermal	16 Min
Thermal Management	Thermal Monitor 1

#### • Delay Prior to Thermal

The Delay Prior To Thermal BIOS feature controls the activation of the Thermal Monitor's automatic mode. It allows you to determine when the Thermal Monitor should be activated in automatic mode after the system boots.

### 3-3. Advanced Chipset Features

This section allows you to configure the system based on the specific features of the installed chipset. This chipset manages bus speeds and the access to the system memory resources, such as DRAM and the external cache. It also coordinates the communications with the PCI bus. It must be stated that these items should never be altered. The default settings have been chosen because they provide the best operating conditions for your system. You might consider making any changes only if you discover that the data has been lost while using your system.

Item	Available Options:
>DRAM Clock/Drive Control	Press Enter
>AGP & P2P Bridge Control	Press Enter
Memory Hole	Disabled
System BIOS Cacheable	Enabled
Video RAM Cacheable	Enabled
Init Display First	AGP

#### DRAM Clock/Drive Control

Item	Available Options:
Current FSB Frequency	
Current DRAM Frequency	
DRAM Clock	By SPD
DRAM Timing	Auto By SPD

#### • DRAM Clock

This item allows you to set the speed of Direct Memory Access (DMA) at either equal to or one-half of the SYSCLK (system clock signal) speed.

<Choice: By SPD, 200MHz, 266MHz>

#### • DRAM Timing

The value in this field depends on performance parameters of the installed memory chips (DRAM). Do not change the value from the factory setting unless you install new memory that has a different performance rating than the original DRAMs.

#### AGP & P2P Bridge Control

Item	Available Options:
AGP Aperture Size	128M
VGA Share Memory Size	64M
Direct Frame Buffer	Enabled
Select Display Device	CRT

#### • AGP Aperture Size (MB)

This function determines the amount of system memory that is given to the AGP card. This is a dynamic memory allotment in that the AGP card will only use the amount of memory that it needs. The remaining memory, which is not in use, will be available for the system.

<Choice: 32MB, 64MB, 128MB, 256MB, 512MB, 1G>

#### • VGA Share Memory Size

This field is used to select the onboard VGA's frame buffer size that is shared from the system memory.

<Choice: Disabled, 16M, 32M, 64M>

#### • Select Display Device

This field is used to select the type of display to use when the system boots.

<Choice: CRT>

### 3-4. Integrated Peripherals

The IDE hard drive controllers support up to two separate hard drives. These drives have a master/slave relationship that is determined by the cabling configuration used to attach them to the controller. Your system supports two IDE controllers--a primary and a secondary--so you can install up to four separate hard disks.

#### Integrated Peripherals

Item	Available Options:
>VIA OnChip IDE Device	Press Enter
>VIA OnChip PCI Device	Press Enter
>SuperIO Device	Press Enter
Onboard Serial Port 3	3E8
Serial Port 3 Use IRQ	IRQ5
Onboard Serial Port 4	2E8
Serial Port 4 Use IRQ	IRQ5
Onboard Parallel Port 2	278
Parallel Port 2 Use IRQ	IRQ9
Parallel Port 2 Mode	ECP+EPP1.9
LPT2 ECP Mode Use DMA	3

#### VIA OnChip IDE Device

Item	Available Options:
OnChip SATA	Enabled
SATA Mode	IDE
OnChip IDE Channel0	Enabled
OnChip IDE Channel1	Enabled
IDE Prefetch Mode	Enabled
Primary Master PIO	Auto
Primary Slave PIO	Auto
Secondary Master PIO	Auto
Secondary Slave PIO	Auto
Primary Master UDMA	Auto
Primary Slave UDMA	Auto
Secondary Master UDMA	Auto
Secondary Slave UDMA	Auto
IDE HDD Block Mode	Enabled

- **SATA Mode**

These fields are used to select the RAID/IDE mode of the serial ATA drives.  
<Choice: RAID, IDE>

- **IDE Primary Master/Slave PIO and IDE Secondary Master/Slave PIO**

The four IDE PIO (programmed Input/Output) fields let you set a PIO mode (0-4) for each IDE device that the internal PCI IDE interface supports. Modes 0 through 4 provide successively increased performance. In Auto mode, the system automatically determines the best mode for each device.

- **IDE Primary Master/Slave UDMA and IDE Secondary Master/Slave UDMA**

These fields allow you to set the Ultra DMA in use. When Auto is selected, the BIOS will select the best available option after checking your hard drive or CD-ROM.

- **IDE HDD Block Mode**

Block mode is also called block transfer, multiple commands, or multiple sectors read/write.

#### VIA OnChip PCI Device

Item	Available Options:
VIA OnChip LAN	Enabled
Onboard LAN Boot ROM	Disabled
OnChip USB Controller	All Enabled
OnChip EHCI Controller	Enabled
USB Emulation	ON
USB Keyboard Support	Enabled

- **VIA OnChip LAN**

This field can enable or disable onboard LAN function.

- **Onboard LAN Boot ROM**

By default, this field is disabled. Enable this field if you wish to use the boot ROM (instead of a disk drive) to boot-up the system and access the local area network directly.

### • USB Emulation

Enable or disable the system's support for the USB port in DOS mode.

<Choice: Off, KB/MS, On>

### • USB Keyboard Support

If USB Emulation is set at KB/MS, this item allows you to enable/disable the USB keyboard/mouse support.

SuperIO Device	
Item	Available Options:
Onboard Serial Port 1	3F8/IRQ4
Onboard Serial Port 2	2F8/IRQ3
UART Mode Select	Normal
RxD, TxD Acitve	Hi,Lo
IR Transmission Delay	Enabled
UR2 Duplex Mode	Half
Use IR Pins	IR-Rx2Tx2
Onboard Parallel Port	378/IRQ7
Parallel Port Mode	Normal
EPP Mode Select	EPPI.7
ECP Mode Use DMA	1

### • UART Mode Select

Select an operating mode for the serial port.

<Choice: IrDA, ASKIR, Normal>

### • Parallel Port Mode

Set the parallel port mode.

<Choice: SPP, EPP, ECP, ECP + EPP, Normal>

## 3-5. Power Management Setup

The Power Management Setup allows users configuring the system to save energy in a most effective way while operating in a manner consistent with their own style of computer use.

Item	Available Options:
ACPI function	Enabled
ACPI Suspend Type	S1(POS)
Power Management Option	User Define
HDD Power Down	Disabled
Suspend Mode	Disabled
Video Off Option	Suspend -> Off
Video Off Method	V/H SYNC+Blank
Soft-Off by PWRBTN	Instant-Off
Run VGABIOS if S3 Resume	Auto
AC Loss Auto Restart	Off
>IRQ/Event Activity Detect	Press Enter

### • ACPI Function

This function should be enabled only in operating systems that support ACPI. Currently, only Windows® 98SE/2000/ME/XP supports this function. When this field is enabled, the system will ignore the settings in the "Suspend Mode" and "HDD Power Down" fields. If you want to use the Suspend to RAM function, make sure this field is enabled then select "S3 (STR)" in the field below.

### • ACPI Suspend Type

This field is used to select the type of Suspend mode.

S1(POS)	Enables the Power On Suspend function.
S3(STR)	Enables the Suspend to RAM function.
S1 & S3	If S3 state is supported by the system, by default [S3] is automatically selected. Otherwise [S1] is selected.

### • Run VGABIOS if S3 Resume

Select whether to run VGA BIOS if resuming from S3 state. This is only necessary for older VGA drivers.

<Choice: Auto, Yes, No>

### IRQ/Event Activity Detect

Item	Available Options:
PS2KB Wakeup Select	Hot key
PS2KB Wakeup from S3/S4/S5	Disable
PS2MS Wakeup from S3/S4/S5	Disabled
USB Resume from S3	Disabled
PowerOn by PCI Card	Enabled
Modem Ring Resume	Enabled
RTC Alarm Resume	Disabled
Date (of Month)	0
Resume Time (hh:mm:ss)	0: 0: 0

#### • PS2KB Wakeup Select

When selecting "Password", press <Enter> to change password. The maximum number of characters is eight. "PS2KB Wakeup from S3/S4/S5" and "PS2MS Wakeup from S3/S4/S5" will be disabled while changing the password.

<Choice: Hot Key, Password>

### 3-6. PnP/PCI Configurations

This section describes the configuration of the PCI bus system. PCI is a system that allows I/O device to operate at speeds nearing the speed of the CPU itself, when communicating with its own special components. This section covers some very technical items. It is strongly recommended that only experienced users make any changes to the default settings.

Item	Available Options:
PNP OS Installed	No
Reset Configuration Data	Disabled
Resources Controlled By	Auto(ESCD)
>IRQ Resources	Press Enter
IRQ-3 assigned to	Reserved
IRQ-4 assigned to	Reserved
IRQ-5 assigned to	PCI Device
IRQ-7 assigned to	Reserved
IRQ-9 assigned to	PCI Device
IRQ-10 assigned to	PCI Device
IRQ-11 assigned to	PCI Device
IRQ-12 assigned to	PCI Device
IRQ-14 assigned to	PCI Device
IRQ-15 assigned to	PCI Device
Assign IRQ For VGA	Enabled
Assign IRQ For USB	Enabled

#### • Reset Configuration Data

Enabled	The BIOS will reset the Extended System Configuration Data (ESCD) once automatically. It will then recreate a new set of configuration data.
Disabled	The BIOS will not reset the configuration data.

#### • Reset Controlled By

Auto(ESCD)	The system will automatically detect the settings for you.
Manual	Choose the specific IRQ in the "IRQ Resources" field.

### 3-7. PC Health Status

This screen shows the information of temperature, Fan speed and Vcore etc. It also can set CPU warning temperature to protect CPU.

#### PC Health Status

Item	Available Options:
Current System Temp.	
Current CPUFan1 Speed	
Current CPUFan2 Speed	
Vcore	
+3.3V	
+ 5 V	
+12 V	
VBAT (V)	
5VSB (V)	

- **CPU Warning Temperature**

Select the combination of lower and upper limits for the CPU temperature, if your computer contains an environmental monitoring system. If the CPU temperature extends beyond either limit, any warning mechanism programmed into your system is activated.

- **Shutdown Temperature**

Select the combination of lower and upper limits for the system shutdown temperature, if your computer contains an environmental monitoring system. If the temperature extends beyond either limit, the system shuts down.

### 3-8. Frequency / Voltage Control

#### Frequency/Voltage Control

Item	Available Options:
CPU Clock Ratio	
Auto Detect PCI Clk	Enabled
Spread Spectrum	Disabled
CPU Clock	100MHz

- **CPU Clock Ratio**

This item is for CPU Ratio adjustment.

- **Auto Detect PCI Clk**

When enabled, the system will automatically send clock signals to existing PCI devices.

- **Spread Spectrum**

Leave this field in its default setting. Do not alter this setting unless advised by an engineer or technician.

## Chapter 4. VGA Feature

### 4-1. VGA Feature

ENDAT-7500M/7515M provides integrated S3 Graphics UniChrome™ Pro IGP, featuring a 2D/3D AGP8X graphics core with integrated MPEG-2 decoding for smooth DVD and digital video playback, the VIA C7® processing platform also features support for high bandwidth DDRII 400/533 memory, motion compensation and DuoView for the latest multiple format flat panel display devices.

With an internal data flow equivalent to what is available to the latest AGP 8X graphics cards, Unichrome Pro IGP has separate 128-bit data path between the North Bridge for pixel data flow and texture/command access. Separate 128-bit 2D and 3D graphics engines ensure optimal performance for all multimedia, entertainment, and productivity applications.

Unichrome Pro IGP includes native support for the most popular digital video and audio playback through hardware MPEG-2 acceleration and acclaimed VIA Vinyl Audio suite, delivering spectacular playback for entertainment devices.

The on-board Graphics Controller supports a full AGP implementation internally to remain compatible with existing software and programming models. However, since the engine is integrated, it enjoys a higher bandwidth and lower latency than is possible with discrete solutions.

The controller of ENDAT-7500M/7515M supports 1 types of display: CRT only.

- Support CRT resolutions up to 1600x1200

### 4-2. Driver Utility Installation Guide

1. When finishing the installation of Windows platform (2000/XP), please install the relative VIA driver (4in1) utilities for compliance compatibility of hardware environment.
2. Insert the support CD that supplied with motherboard into CD-ROM driver which enable the access with auto-run mode; or double –click the CD driver icon in “My Computer” to bring up the screen.
3. Select correct motherboard to install driver / utility for the system



4. Select VIA 4in1 service pack driver install to the system

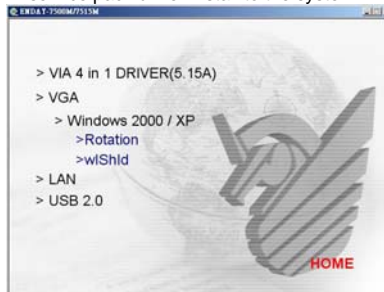

5. The Screen will appear VIA 4in1 driver setup screen, please press "NEXT" to continue. Please follow the steps instructed by each screen for the installation of the VIA 4in1 driver. Restart the system after completed the installation.
6. After installing the VIA 4in1 driver, please select VGA driver for install. The system will request for "restart" after the completion of the driver installation.
7. The Screen can be adjusted at Display properties after the installation of VGA driver.

*We strongly recommend using the 4in1 driver to install the system since the 4in1 driver will automatically detect / update the necessary drivers.*

This driver will automatically detect and install the latest utilities as following:

**IDE Bus master, VIA AGP Driver, IRQ Routing Driver, VIA INF Driver**

**LAN Driver:** Install the LAN driver for on-board LAN adapter.

**VGA Driver:** Install the VGA driver for on-board AGP VGA adapter

*Please download or check from VIA Web site: [www.via.com.tw](http://www.via.com.tw) if you prefer to install the drivers individually or you need more information.*

## Chapter 5. LAN Adapter

The on-board LAN adapter integrated of Single Chip Fast Ethernet Controller with options of one or dual LAN solution, and also the LAN chip option of VIA VT6103 solution. It is highly integrated and requires no "glue" logic external memory on board. It runs in the bus master mode and directly sending/receiving Ethernet packet to/from memory. The On-board LAN adapter can directly fetch the system CPU. Also, it can transfer data Directly between I/O devices and system memory in the 32-bit bus master mode that provides low CPU utilization.

It complies with the IEEE 802.3x standard, IEEE802.3 standard and PCI Local Bus version 2.1 and transmits data on the network at 100 Mbps or 10 Mbps. It also operates in full-duplex mode that **doubles the network speed up to 20/200 Mbps when working with Fast Switching Hub**. Built-in one RJ-45 port for connection of 100Base-TX Fast Ethernet or 10Base-T Ethernet network, and automatically senses the connection type.

### 5-1. Features

- Full compliancy with PCI Rev. 2.1
- Complies with the Ethernet/IEEE 802.3u 100Base-TX and 10 Base-T industry standard
- Supports full-duplex operations, thus doubling the network speed up to 20Mbps on 10 Base-T Ethernet or 200Mbps on 100 Base-TX Fast Ethernet when setting in full duplex mode
- Two LED indicators to report network status
- One RJ-45 connector with Auto-sense cable type of 10 or 100Mbps network operation
- Supports PCI clock speed up to 33MHz, capable of zero wait states
- Supports Remote Boot ROM by system BIOS
- Provides a comprehensive setup program for displaying the adapter configuration and includes diagnostic on board or network tests
- Complete drivers for Novell, Windows NT and Windows 95/98 Packet driver etc

## 5-2. UTP Cable / RJ-45 Jack Definition

Straight through twisted pair cable is typically used to connect a hub to a server or workstation. In a straight through connection, Pin 1 at the server, Pin 2 at the hub connects to Pin 2 at the server, and so on. Figure A-1 shows the locations of pins on a standard RJ-45 plug on a twisted-pair cable.

Table A-1 shows the wiring in a straight-through twisted-pair cable (Pins 4, 5, 7 and 8 are not used).

Twisted Pair Number	Pin Number	Signal Description	To	Pin Number	Signal Description
1	1	TD+	→	1	TD+
	2	TD-		2	TD-
2	3	RD+	→	3	RD+
	6	RD-		6	RD-

### RJ-45 Connector Pin Assignments

Figure A-1 shows the RJ-45 Connector pin assignments

RJ45 PIN AND CABLE COLORS

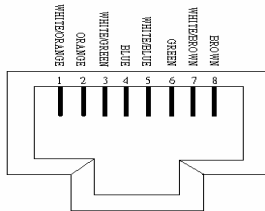

## 5-3. Connecting 100Base-TX Fast Ethernet Network

The system board provides an RJ-45 port for connection to 100Base-TX Fast Ethernet or 10Base-T Ethernet Network with a single connection over unshielded twisted-pair (UTP). The adapter automatically operates at 10Mbps or 100Mbps when the appropriate 10/100Base hub is connected.

To connect the adapter to 100Base-TX Fast Ethernet Network, you need a twisted-pair Category 5 cable with RJ-45 modular jacks at both ends. This cable can have a maximum length of 300 feet (100 meters).

## 5-4. Connecting 10Base-T Ethernet Network

To connect the adapter to a 10Base-T Ethernet Network, you need a twisted-pair Category 3, 4 or 5 cables with RJ-45 modular jacks at both ends. This cable can have a maximum length of 300 feet (100 meters).

## 5-5. 10MBase/100MBase Installation Notice

- 100Mbps network must be shielded twisted-pair (STP) or Category 5 unshielded twisted-pair cable. Do not use a Category 3 or 4 cable for 100Mbps-network operation, it could cause data loss. Category 3 or 4 cable is good for 10Mbps network only.
- Category 5 cable is also good for 10Mbps operation. Use UTP Category 5 cable for the versatility to operate the network at either 100Mbps or 10Mbps speed without changing cable.
- Two pairs of wiring are required.
- Depending on building codes, different insulation materials may be required. Plenum-rated or TEFLON-coated wiring maybe required in some areas where fireproofing is required.
- The wire gauge should be between 18 and 26 AWG (Most telephone installations use 24-gauge wiring).
- UTP cable should meet the following requirements:
  1. Solid copper
  2. Nominal capacitance: less than 16pF/ft
  3. Nominal impedance: 100 ohms
  4. Nominal attenuation: less than 11.5db

### Automatic Selection of the Media Type

While the driver installs, it automatically detects the media type based on the type of cable connected. Once you change the cable type, you must reinstall the driver to execute auto-detect again.

**If the driver cannot detect which cable is connected or whether a cable is connected, look at cabling network driver (Ex. Modify net.cfg file parameters—force line speed=10 or 100).**

### 10/100 Auto – Negotiation (N-Way)

Depending on the hub or connected device, the LAN adapter can automatically run at the appropriate speed, by using N-way, a feature that complies with the IEEE802.3 standard. It also works with any of the other IEEE-compliant products.

### 5-6. Remote BOOT ROM function

This function is available with the BIOS programming for indicated operation system. The remote boot function allows the computer to boot up over the network, instead of using the local operating system device. This enables the system to be a diskless workstation environment.

### 5-7. LED Indicators

The system board comes with two LED indicators on the edge of the motherboard that indicates the network system status. If you experience any problems with the adapter, first make sure the appropriate driver is loaded, the proper cable is connected to the RJ-45 port and the hub complies with the adapter specification, such as 10Mbps 10Base-T or 100Mbps 100Base-TX. Finally, recheck the LEDs.

### FUDUP (Full Duplex) Indicator

When indicator is ON, it indicates Full-duplex mode; otherwise, it is OFF. The adapter supports full duplex at 10 or 100Mbps. If the switch-hub supports the N-way feature and full duplex, the system will automatically run in full duplex mode.

### Tx/Rx (Transmit/Receiver) Indicator

This indicator flashes to display that there is network activity – indicating transmission or reception data from the network.

## Appendix A: FLASH Memory Utility

Using this utility to update the system BIOS from a disk file to the on board Flash memory. Be aware the improper change of the system BIOS will cause the system to malfunction.

Using utility as follows:

1. Insert the FLASH memory utility distribution floppy diskette in drive A:
2. At the DOS prompt, type A:>AWDFLASH and press <Enter>

AwardBIOS FLASH Utility V8.36E C>Phoenix Technologies Ltd. All Rights Reserved	
Flash Type –	
File Name to Program:	<input type="text"/>
Message:	

3. Enter the name of the system BIOS disk file into the "File Name to Program" field.

The following message appears in the "Message" field

4. Do you want to save BIOS (y/n)?
5. To update the FLASH memory from the system BIOS disk file, type Y
6. After complete updating, please re-boot the system (press "F1" key)
7. For upgrade BIOS procedure, please refer to our web site:  
<http://www.unicorn-computer.com.tw>

\* Please turn off system and clear CMOS data by JBAT1.

\* Please restart your system and load optimal defaults setting.



● **Issue Code of defect.**

01	Second Times R.M.A.	11	Memory Socket Bad
02	No Screen (No Boot)	12	Hang Up Hardware
03	VGA (Display) Fail	13	Hang Up Software
04	CMOS Data Lost	14	PCB Problem
05	FDC Fail	15	CPU Socket Bad
06	HDC Fail	16	LAN Fail
07	Bad Slot	17	Audio Fail
08	BIOS Problem	18	Serial Port Fail
09	Keyboard Controller Fail	19	Parallel Port Fail
10	Cache RAM Problem	20	Others

Please specify the following when returning the RMA boards:

(1) Hardware Configuration (2) OS or Software (3) Testing Program

\_\_\_\_\_  
Authorized Signature